

Development and Integration Support

To facilitate application integration and development, FPC provides a range of development and breakout boards. These are available in two formats:

- ⊗ Complete Development Kits:
 - Include all components required to begin development immediately.
- ⊗ Individual Boards:
 - Designed for flexible use in various development environments.

Some development boards, like the FingerWing, are pre-mounted with an AllKey Biometric System component, enabling rapid prototyping and evaluation. Generic boards are engineered to support common industry standards, such as the Feather Wing and Arduino Shield form factors, ensuring broad compatibility and ease of integration.

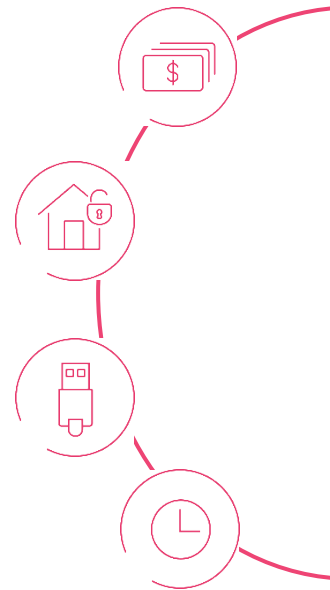
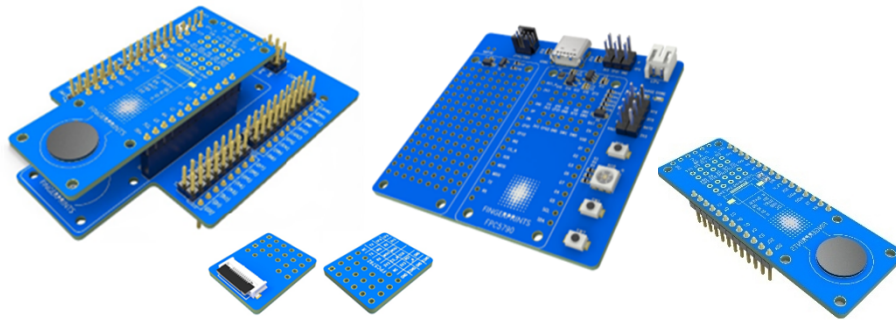

Range of Development boards

This document provides an overview of the development boards available for integration and prototyping within the FPC ecosystem. It includes descriptions of product-specific FingerWing boards, and a selection of support boards designed to simplify hardware interfacing and accelerate application development. Each board type serves a distinct purpose, from enabling direct access to biometric system signals to offering compatibility with common industry form factors such as Feather Wing and Arduino Shield.

- ⊗ FPC AllKey Development kit
- ⊗ FPC AllKey Pro Development kit
- ⊗ FPC AllKey Open Platform Development kit
- ⊗ FPC AllKey Ultra Development kit

- ⊗ FPC5789 AllKey FingerWings - for the FPC2530 and FPC2540 series
- ⊗ FPC5793 AllKey Ultra FingerWings - for the FPC3530 series
- ⊗ FPC5795 AllKey Ultra Edge FingerWings - for the FPC3510 series
- ⊗ FPC5788 Arduino Shield mating with a FingerWing
- ⊗ FPC5790 FingerTwin with dual FingerWing space and USB power supply
- ⊗ FPC5792 Flex module breakout board

Operational details on Biometric System specific boards, can be found in the dedicated product documentation.

Table of Contents

1	ALLKEY DEVELOPMENT KITS	4
1.1	Overview	4
2	ALLKEY DEVELOPMENT BOARD COMPATIBILITY.....	5
3	FINGERWING – FINGERPRINT SENSOR ON FEATHER WING.....	6
3.1	Common FingerWing features	6
3.1.1	Overview	6
3.1.2	Product outline.....	6
3.1.3	Interface selection.....	7
3.2	FPC5789 AllKey FingerWing	8
3.2.1	Pin configuration.....	8
3.2.2	Functional schematic	9
3.3	FPC5793 AllKey Ultra FingerWing	10
3.3.1	Pin configuration.....	10
3.3.2	Functional schematic (including bridge component).....	11
3.4	FPC5795 AllKey Ultra Edge FingerWing.....	12
3.4.1	Pin configuration.....	12
3.4.2	Functional schematic	13
4	FPC5788 SHIELD - ARDUINO SHIELD BOARD.....	14
4.1	Overview	14
4.2	Default setup.....	14
4.3	DEEP SLEEP wakeup in UART mode	14
4.4	Product outline	15
4.5	Functional schematic	16
4.6	Pin configuration.....	17
4.7	Interface selection.....	18
5	FPC5790 FINGERTWIN	19
5.1	Overview	19
5.2	Default setup.....	19
5.3	Monitoring BAT voltage	19
5.4	RGB led and micro switches	19
5.5	Product outline	20
5.6	Functional schematic	21
5.7	Prototype area	22
5.8	Interface selection.....	22
6	FPC5792 FLEX (12P) BREAKOUT BOARD	23
6.1	Overview	23
6.2	Product outline	23
6.3	Functional schematic	23
6.4	Pin configuration.....	24



2025-12-02

Biometric Systems Development Accessories

6.5	Interface selection and ESD discharge path	24
6.6	DEEP SLEEP wakeup in UART mode	24
7	ORDERING INFORMATION	25
7.1	Device name and Part numbers	25
7.2	Production codes	25
7.3	Shipping format.....	25
7.4	ESD sensitive device	25
8	REVISION HISTORY	26
8.1	Product specification (this document)	26
9	CONTACT INFORMATION	26

1 ALLKEY DEVELOPMENT KITS

1.1 Overview

To accelerate application development, FPC offers Development Kits that include all essential components for rapid prototyping and evaluation. Each kit is delivered in a branded FPC package and contains everything required to get started immediately.

Development Kits exists in two configurations:

- ⊗ AllKey product specific FingerWing + Arduino Shield board
- ⊗ AllKey product specific FingerWing + FPC FingerTwin with USBC connection

These kits are designed to simplify integration, reduce setup time, and provide a complete hardware platform for testing and development. Detailed description of individual boards are provided in subsequent sections of this document.

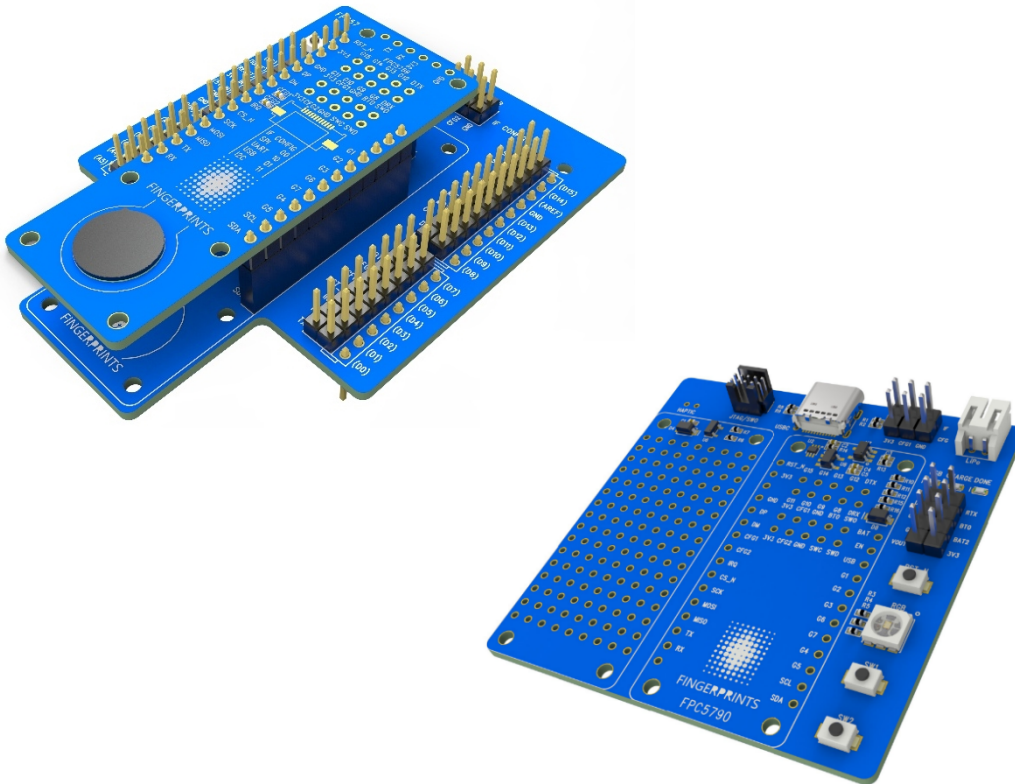

2 ALLKEY DEVELOPMENT BOARD COMPATIBILITY

The overview below illustrates the compatibility between AllKey products, and available development boards and Devkit bundles to support application development.

AllKey product	Product formfactor	Available Devkit	AllKey product is compatible with/or mounted on:			
			FingerWing	Shield	FingerTwin	Flex breakout
FPC2532AP	LGA package	AllKey Devkit	Yes	-	-	-
FPC2534AP	LGA package	AllKey Pro Devkit	Yes	-	-	-
FPC2541AP	LGA package	AllKey OPA Devkit	Yes	-	-	-
FPC3530AP	LGA package	AllKey Ultra Devkit	Yes	-	-	-
FPC2532AM	Flex module		-	Yes*	-	Yes
FPC2534AM	Flex module		-	Yes*	Yes**	Yes
FPC2541AM	Flex module		-	-	Yes**	-
FPC5789-2532	FingerWing		-	Yes	-	-
FPC5789-2534	FingerWing		-	Yes	Yes	-
FPC5789-2541	FingerWing		-	Yes	Yes	-
FPC5793-3530	FingerWing		-	Yes	Yes	-
FPC5795-3510	FingerWing		-	Yes	Yes	-

(*) NOTE: Shield is equipped with a 12 pin ZIF connector.

(**) NOTE: Can be connected to the FingerTwin with a separate adapter board.

3.1.3 Interface selection

Interface configuration can be set in SW or manually (hard wired) on the FingerWing with wire jumpers. Correct configuration for each interface may differ for different LGA products but in general the below table apply. For a detailed description of available interfaces, refer to the corresponding Biometric System specification.

INTERFACE	IF_CFG_1	IF_CFG_2
SPI	LOW	LOW
UART	HIGH	LOW
USB	LOW	HIGH
I ² C	HIGH	HIGH

The onboard interface selection pin, CFG1 and CFG2 are located in the breakout header close by 3V3 and GND. Note that these two signals (CFG1* and CFG2*) are connected to the corresponding CFG1 and CFG2 in the FingerWing header via 100k resistors. This to avoid signal shortage, if SW settings are accidentally applied on top of a manual interface selection. No wire jumpers are mounted on delivery. If the FingerWing is used together with a shield board, manual configuration can also be done directly on the shield.

SPI interface set:

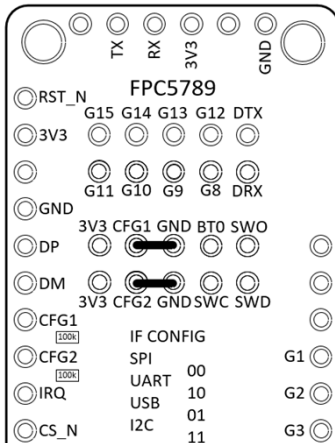

UART interface set:

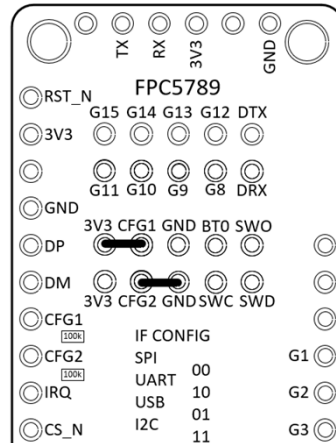

3.2 FPC5789 AllKey FingerWing

3.2.1 Pin configuration

Left fingerwing headers (16 pin):

PIN	NAME	SIGNAL
1	RST_N	RST_N
2	3V3	3V3
3	NC	Not used
4	GND	GND
5	DP	USB_DP
6	DM	USB_DM
7	CFG1	IF_CFG_1
8	CFG2	IF_CFG_2
9	IRQ	IRQ
10	CS_N	SPI_CS_N
11	SCK	SPI_SCK
12	MOSI	SPI_MOSI
13	MISO	SPI_MISO
14	TX	UART_TX (to host RX)
15	RX	UART_RX (to host TX)
16	NC	Not used

Top breakout header (10 pin):

PIN	NAME	SIGNAL
1	G11	GPIO_11
2	G15	GPIO_15
3	G10	GPIO_10
4	G14	GPIO_14
5	G9	GPIO_9
6	G13	GPIO_13
7	G8	GPIO_8
8	G12	GPIO_12
9	DRX	DBG_UART_RX
10	DTX	DBG_UART_TX

Serial adapter board interface (6 pin):

PIN	NAME	NOTE
1	NC	Not used
2	TX	UART_TX (to host RX)
3	RX	UART_RX (to host TX)
4	3V3*	
5	NC	Not used
6	GND	GND

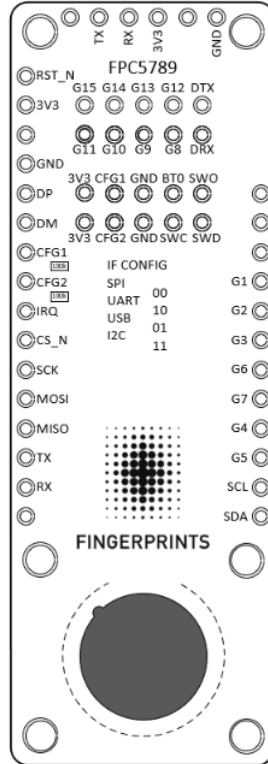

Right fingerwing headers (12 pin):

PIN	NAME	SIGNAL
-		
-		
-		
-		
1	NC	Not used
2	NC	Not used
3	NC	Not used
4	G1	GPIO_1
5	G2	GPIO_2
6	G3	GPIO_3
7	G6	GPIO_6
8	G7	GPIO_7
9	G4	GPIO_4
10	G5	GPIO_5
11	SCL	I2C_SCL
12	SDA	I2C_SDA

Bottom breakout header (10 pin):

PIN	NAME	SIGNAL
1	3V3	3V3
2	3V3	3V3
3	CFG1	to CFG1 via 100k
4	CFG2	to CFG2 via 100k
5	GND	GND
6	GND	GND
7	SWC	DBG_SWCLK
8	BT0	BOOT0
9	SWD	DBG_SWO
10	SWO	DBG_SWDIO

(*) NOTE: Only adapter boards supporting 3V3 supply voltage can be used. Connecting 5V power supply may damage the device.

3.2.2 Functional schematic

All signals from the LGA are available in one or more headers in order to support the feather wing standard as well as commonly used USB to UART adaptors (FTDI). Remaining signals are made available in the two 10p breakout headers (not mounted). Some older AllKey FingerWing boards also include a ZIF connector, but this has been removed in later versions.

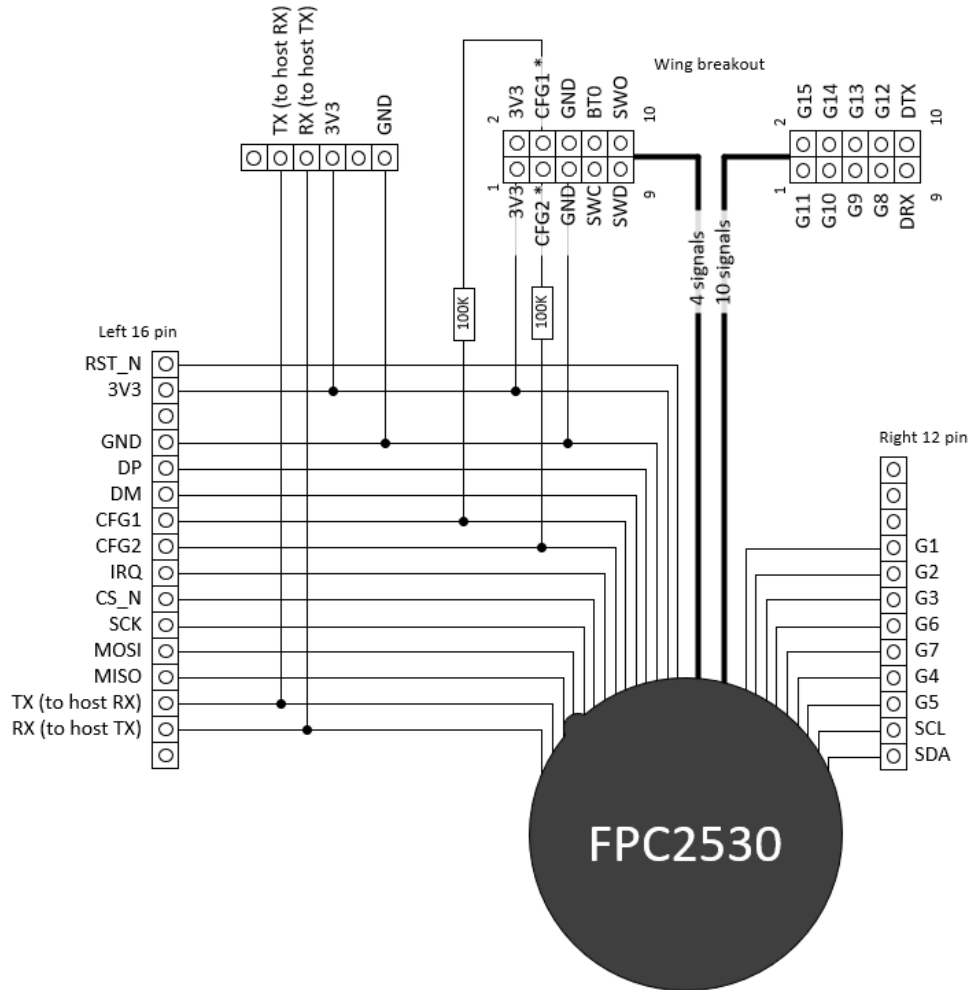

3.3 FPC5793 AllKey Ultra FingerWing

3.3.1 Pin configuration

Left fingerwing headers (16 pin):

PIN	NAME	SIGNAL
1	RST_N	RST_N
2	3V3	3V3
3	Not used	Not used
4	GND	GND
5	DP	USB_DP
6	DM	USB_DM
7	CFG1	IF_CFG_1
8	CFG2	IF_CFG_2
9	IRQ	IRQ
10	CS_N	SPI_CS_N
11	SCK	SPI_SCK
12	MOSI	SPI_MOSI
13	MISO	SPI_MISO
14	NC	Not used
15	NC	Not used
16	NC	Not used

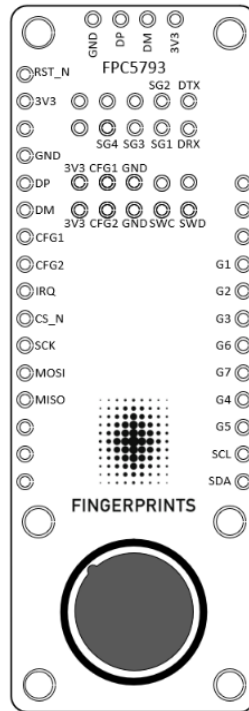

Right fingerwing headers (12 pin):

PIN	NAME	SIGNAL
-		
-		
-		
-		
1	NC	Not used
2	NC	Not used
3	NC	Not used
4	G1	GPIO_1
5	G2	GPIO_2
6	G3	GPIO_3
7	G6	GPIO_6
8	G7	GPIO_7
9	G4	GPIO_4
10	G5	GPIO_5
11	SCL	I2C_SCL
12	SDA	I2C_SDA

Top breakout header (10 pin):

PIN	NAME	SIGNAL
1	NC	Not used
2	NC	Not used
3	SG4	SGPIO_4
4	NC	Not used
5	SG4	SGPIO_3
6	NC	Not used
7	SG4	SGPIO_1
8	SG4	SGPIO_2
9	DRX	DBG_UART_RX
10	DTX	DBG_UART_TX

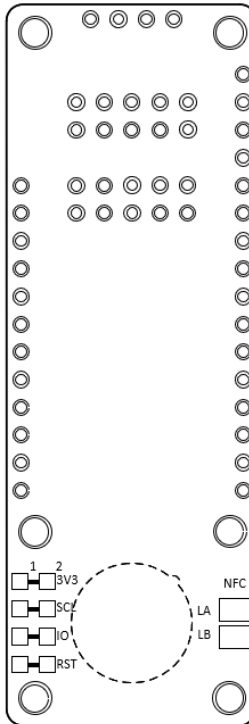

Bottom breakout header (10 pin):

PIN	NAME	SIGNAL
1	3V3	3V3
2	3V3	3V3
3	CFG1	to CFG1 via 100k
4	CFG2	to CFG2 via 100k
5	GND	GND
6	GND	GND
7	SWC	DBG_SWCLK
8	NC	Not used
9	SWD	DBG_SWO
10	NC	Not used

Backside SE connect/ISO (8 pads):

PIN	NAME	NOTE
1,2	3V3/3V31	USB bridge supply
3,4	SCL1/SCL2	ISO signal short
5,6	IO1/IO2	ISO signal short
7,8	RST1/RST2	ISO signal short

Serial adapter board interface (4 pin):

PIN	NAME	NOTE
1	GND	GND
2	DP	USB_DP
3	DM	USB_DM
4	3V3*	

NFC antenna (2 pads):

PIN	NAME	NOTE
1	LA	NFC antenna
2	LB	NFC antenna

(* NOTE: Only adapter boards supporting 3V3 supply voltage can be used. Connecting 5V power supply may damage the device.

3.3.2 Functional schematic (including bridge component)

The FPC3530 component includes the bridge component, allowing multiple interface the be used for communication with the Biometric System.

Signals from the LGA are available in one or more headers in order to support the feather wing standard as well as commonly used adaptor boards. Remaining signals are made available in the two 10p breakout headers (not mounted).

The FPC5793 with an FPC3530 mounted is by default configured to use with the internal bridge component. However this can be disconnected to allow for direct secure element communication (via ISO7816). Only four PCB trace lines on the backside of the FingerWing need to be cut in order to disconnect the bridge from the secure element. This will cut power and also disconnect the bridge from the secure element interface. The secure element will stay powered and SGPIOs are still available in the different headers, but communication with the secure element have to be organized via the three pads: SCL2, IO2 and RST2.

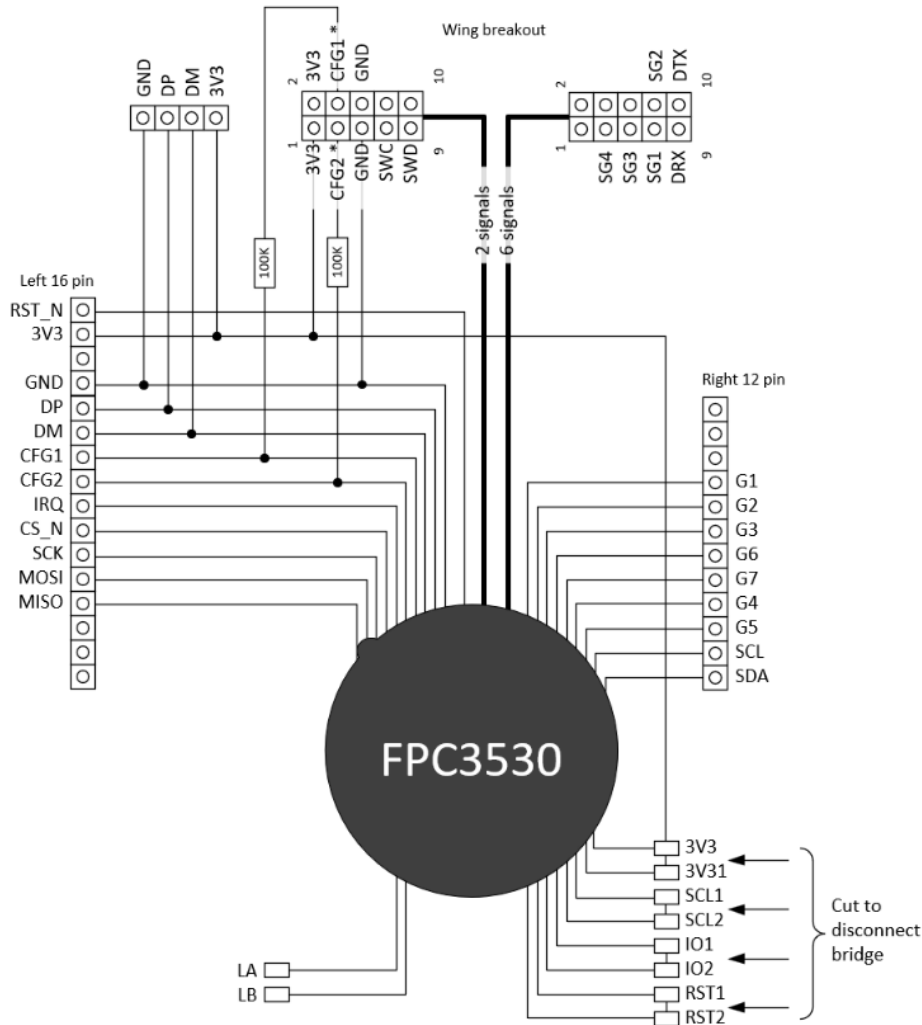

2025-12-02

Biometric Systems Development Accessories

3.4 FPC5795 AllKey Ultra Edge FingerWing

3.4.1 Pin configuration

Left fingerwing headers (16 pin):

PIN	NAME	SIGNAL
1	RST_N	RST_N
2	3V3	3V3
3	Not used	Not used
4	GND	GND
5	DP	USB_DP
6	DM	USB_DM
7	CFG1	IF_CFG_1
8	CFG2	IF_CFG_2
9	IRQ	IRQ
10	CS_N	SPI_CS_N
11	SCK	SPI_SCK
12	MOSI	SPI_MOSI
13	MISO	SPI_MISO
14	NC	Not used
15	NC	Not used
16	NC	Not used

Top breakout header (10 pin):

PIN	NAME	SIGNAL
1	NC	Not used
2	NC	Not used
3	SG4	SGPIO_4
4	NC	Not used
5	SG4	SGPIO_3
6	NC	Not used
7	SG4	SGPIO_1
8	SG4	SGPIO_2
9	DRX	DBG_UART_RX
10	DTX	DBG_UART_TX

Backside SE connect/ISO (5 pads):

PIN	NAME	NOTE
1,2	3V3/3V31	USB bridge supply
3	SCL1/SCL2	ISO signal short
5	IO1/IO2	ISO signal short
7	RST1/RST2	ISO signal short

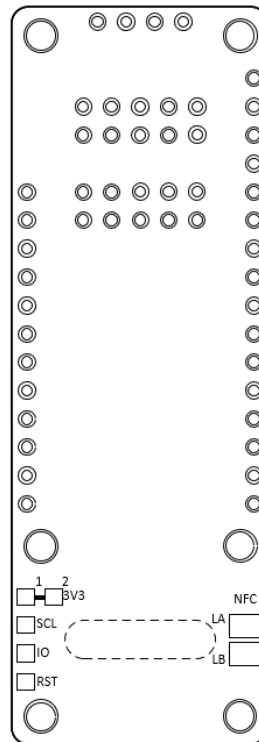
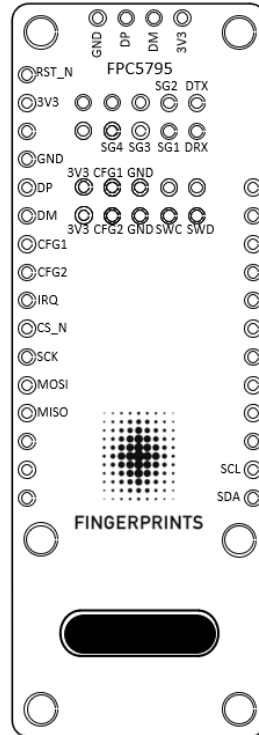

Right fingerwing headers (12 pin):

PIN	NAME	SIGNAL
-		
-		
-		
-		
1	NC	Not used
2	NC	Not used
3	NC	Not used
4	NC	Not used
5	NC	Not used
6	NC	Not used
7	NC	Not used
8	NC	Not used
9	NC	Not used
10	NC	Not used
11	SCL	I2C_SCL
12	SDA	I2C_SDA

Bottom breakout header (10 pin):

PIN	NAME	SIGNAL
1	3V3	3V3
2	3V3	3V3
3	CFG1	to CFG1 via 100k
4	CFG2	to CFG2 via 100k
5	GND	GND
6	GND	GND
7	SWC	DBG_SWCLK
8	NC	Not used
9	SWD	DBG_SWO
10	NC	Not used

Serial adapter board interface (4 pin):

PIN	NAME	NOTE
1	GND	GND
2	DP	USB_DP
3	DM	USB_DM
4	3V3*	

NFC antenna (2 pads):

PIN	NAME	NOTE
1	LA	NFC antenna
2	LB	NFC antenna

(* NOTE: Only adapter boards supporting 3V3 supply voltage can be used. Connecting 5V power supply may damage the device.

3.4.2 Functional schematic

The FPC3510 component includes the bridge component, allowing multiple interface the be used for communication with the Biometric System.

Signals from the LGA are available in one or more headers in order to support the feather wing standard as well as commonly used adaptor boards. Remaining signals are made available in the two 10p breakout headers (not mounted).

The FPC5795 with an FPC3510 mounted is by default configured to use with the internal bridge component.

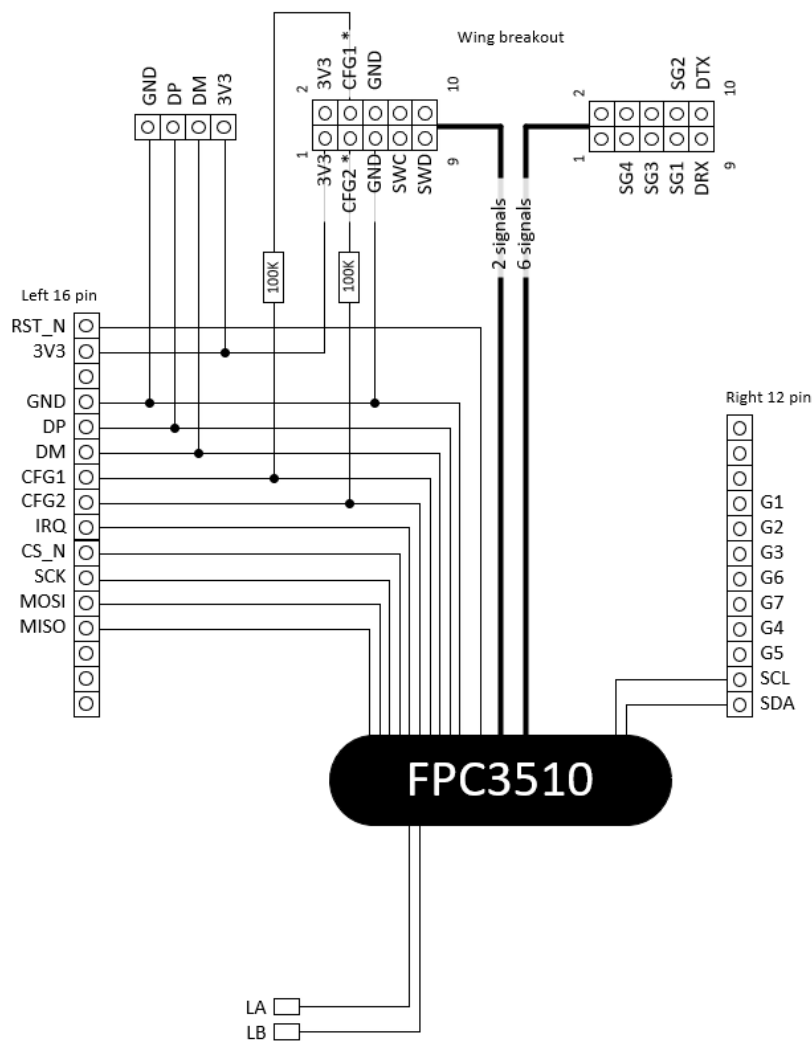

4 FPC5788 SHIELD - ARDUINO SHIELD BOARD

4.1 Overview

The shield board provides connection to the biometric FingerWing, the Arduino shield connector interface, and to a 12pin flex module. The shield also provides access and configuration possibilities to all signals available in the Biometric system. Even though many signals are placed for easy configuration with a jumper, all signals are fully flexible, and the final shield configuration is decided by the customer. The FingerWing is attached on top of the shield.

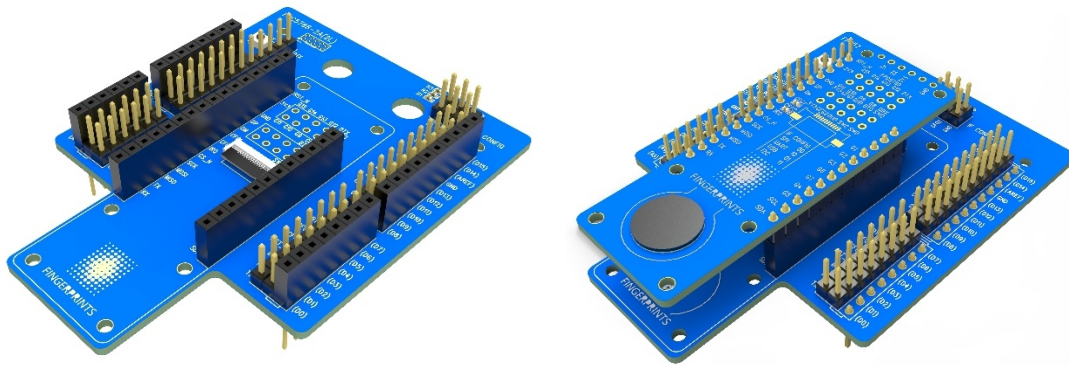

4.2 Default setup

On delivery the shield is setup to work with the FPC example code. Other configurations are possible, but the jumper setting to the right is default.

Pay attention to connect the 3V3_IN to 3V3 (red) and GND to GND (blue) with jumpers since these jumper provides power and ground to the entire board. The 5V_IN is NOT to be used and may damage the Biometric System if connected.

4.3 DEEP SLEEP wakeup in UART mode

The steps to wake up a Biometric system from DEEP SLEEP in UART mode, is described more in detail under the "Interface/UART communication" section in the corresponding Biometric Systems specification. But in general below method can be applied.

As described in the above-mentioned section, if no separate signal is assigned as system wakeup, a dedicated jumper is required between CS_N (SYS_WU in UART mode) and UART_RX. This will allow the system to wake up using only the UART_RX signal.

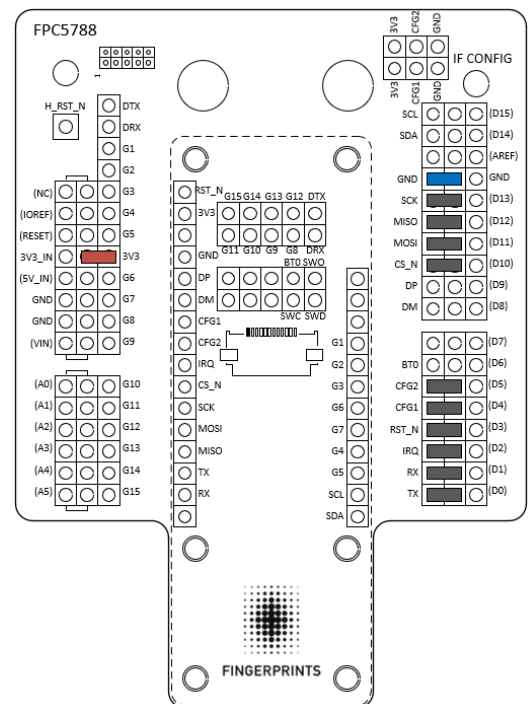
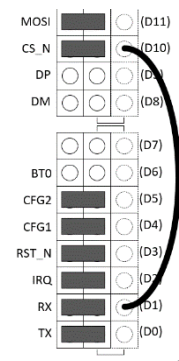

4.4 Product outline

All dimensions are according to the normal shield standard. All mounting holes, including break-out signals, are placed in a 2,54 mm grid, allowing for an easy connection with standard proto boards.

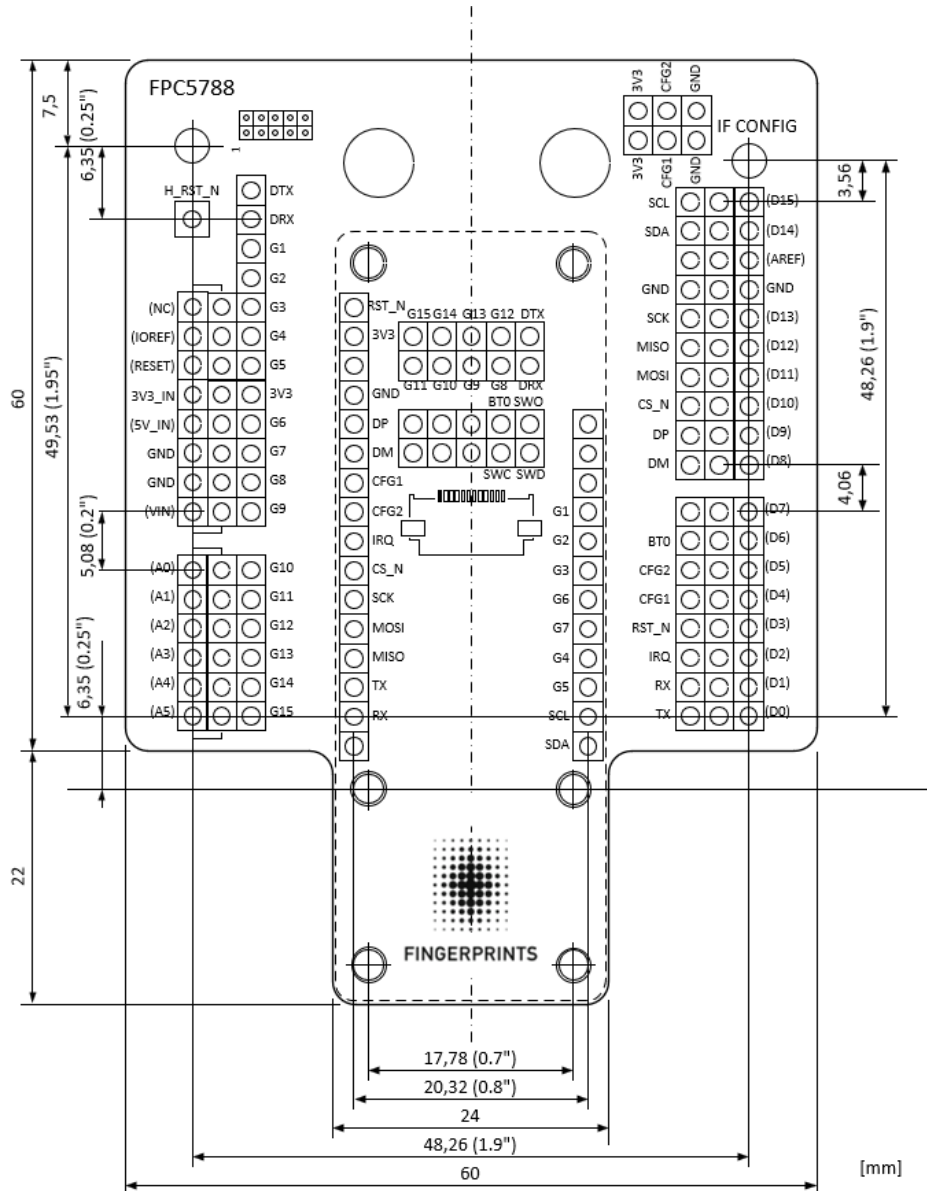

4.5 Functional schematic

All signals coming from the FingerWing are available in headers for easy configuration in the shield interface. To simplify onboard interface selection, CFG1 and CFG2 are also available in a separate header close by 3V3 and GND. Note that these two signals (CFG1* and CFG2*) are connected to the corresponding CFG1 and CFG2 in the shield configuration header via 100k resistors. This to avoid signal shortage, if SW settings are accidentally applied on top of a manual interface selection. Besides headers there is also a system reset micro switch (RST_N) available in the top left of the board. Pressing this one will send a reset signal to the connected Biometric System.

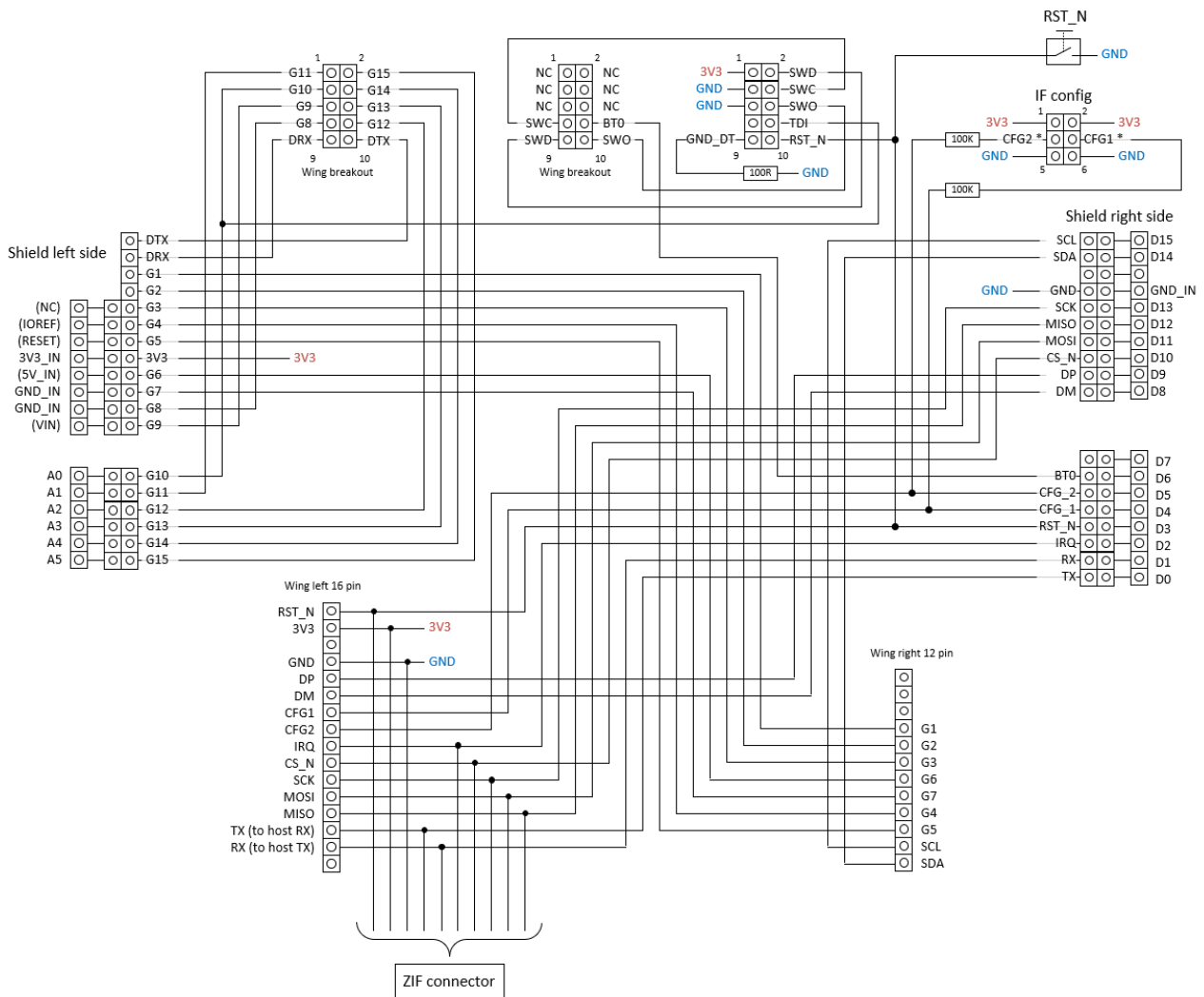

4.6 Pin configuration

Details on signals coming from the FingerWing are described in the respective FingerWing specification.

The four shield headers are built up of three columns, the outer header column represents the standard stackable shield header, center column is one-to-one connected with the first one mounted on the top side facing up. The last column, towards board center, contains signals from the FingerWing and can hence easily be connected to the neighboring shield pin with a jumper, or further away using a jumper cable. Shield interface signals in brackets below are not used in this board setup and should not be connected with jumpers.

Left shield headers (top side signals only):

POS	CENTER Shield signal	RIGHT COL Wing signal	FULL NAME
1		DTX *	DBG_UART_TX
2		DRX *	DBG_UART_RX
3		G1	GPIO_1
4		G2	GPIO_2
5	(NC)	G3	GPIO_3
6	(IOREF)	G4	GPIO_4
7	(RESET)	G5	GPIO_5
8	3V3_IN	3V3	3V3 (shield supply)
9	(5V_IN)	G6	GPIO_6
10	GND	G7	GPIO_7
11	GND	G8	GPIO_8
12	(VIN)	G9	GPIO_9
13	A0	G10	GPIO_10
14	A1	G11	GPIO_11
15	A2	G12	GPIO_12
16	A3	G13	GPIO_13
17	A4	G14	GPIO_14
18	A5	G15	GPIO_15

Right shield headers (top side signals only):

POS	LEFT COL Wing signal	CENTER Shield signal	FULL NAME
1	SCL	D15	I2C_SCL
2	SDA	D14	I2C_SDA
3	Not used	(AREF)	
4	GND	GND	GND (shield ground)
5	SCK	D13	SPI_SCK
6	MISO	D12	SPI_MISO
7	MOSI	D11	SPI_MOSI
8	CS_N	D10	SPI_CS_N
9	DP	D9	USB_DP
10	DM	D8	USB_DM
11	Not used	D7	
12	BT0 *	D6	BOOT0
13	CFG2	D5	IF_CFG_2
14	CFG1	D4	IF_CFG_1
15	RST_N	D3	RST_N
16	IRQ	D2	IRQ
17	RX	D1	UART_RX (to host TX)
18	TX	D0	UART_TX (to host RX)

(*) NOTE: DBG signals and BOOT0 are only for internal use, leave not connected

4.7 Interface selection

Different Biometric System products offers different interfaces. In order to select the desired interface, two configuration pins on the LGA are used. These pins can be hard wired high (3V3) or low (GND) in the final application, when the final interface is selected, assuming only one interface is used.

INTERFACE	CFG1	CFG2
SPI	LOW	LOW
UART	HIGH	LOW
USB	LOW	HIGH
I ² C	HIGH	HIGH

Interface configuration can also be set in SW or manually on the FingerTwin using jumpers. If they are left open (not set), SPI is the default interface. Also pay attention to any hard-wired interface selection done on the FingerWing. Conflicting interface selection will lead to interface malfunction.

SPI interface set:



UART interface set:



5 FPC5790 FINGERTWIN

5.1 Overview

The FingerTwin is a Biometric Systems breakout board with dual finger wing assembly space. All FingerWing signals are easily accessible via headers or through-hole-plated connections. Details on these signals are described in the respective FingerWing specification.

One half of the board is a prototyping space where customer specific accessories can be mounted and evaluated.

The FingerTwin is powered from an USB-C connector. It also includes a LiPo charging circuit allowing for a battery powered stand-alone operation.

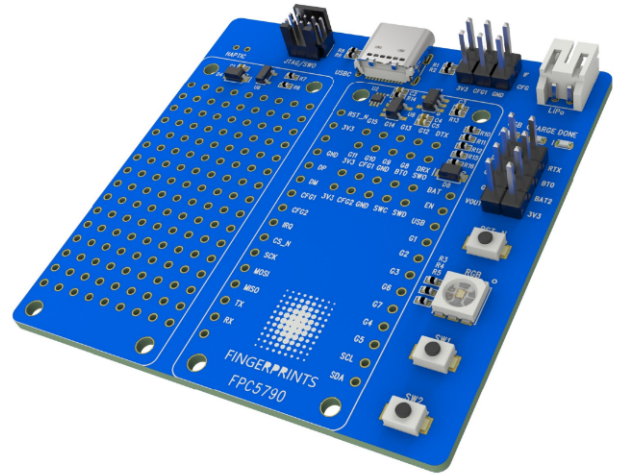

5.2 Default setup

On delivery the FingerTwin is setup to work with the FPC example code. Other configurations are possible, but the RED jumper setting and included headers to the right is default. There is also standard 2 pin JST 2.54mm socket to connect external LiPo batteries. Please pay extra attention to battery polarity (picture on the right) before connecting.

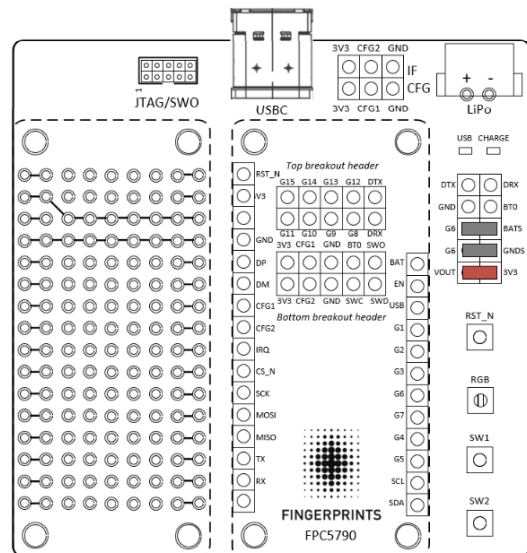

5.3 Monitoring BAT voltage

The FingerTwin is provided with jumpers allowing the user to include a voltage divider to measure BAT voltage, using the G6 pin on the FingerTwin. To add this feature, two jumpers need to be added. Shown in GRAY to the right. This will divide the BAT voltage in half and connect it to the G6 pin as shown in schematic later on.

5.4 RGB led and micro switches

The FingerTwin board comes with an RGB led that can be accessed from the top breakout header. See picture to the right for details. The RGB led is a common anode type and has a 1k resistors in series with each cathode. The GPIO 9, 10 and 12 can be used to control intensity and color of the RGB diode.

Additionally the FingerTwin board contains two micro switches to trigger different functionalities in SW. A third system reset switch is also present.

PIN	NAME	FEATURE
1	G11	Not used
2	G15	Not used
3	G10	RED led segment, active low
4	G14	Not used
5	G9	BLUE led segment, active low
6	G13	Switch no 2
7	G8	Switch no 1
8	G12	GREEN led segment, active low
9	DRX	Debug signal
10	DTX	Debug signal

5.5 Product outline

All mounting holes, including break-out signals and prototype area, are placed in a 2,54 mm grid, allowing for an easy connection with standard proto boards.

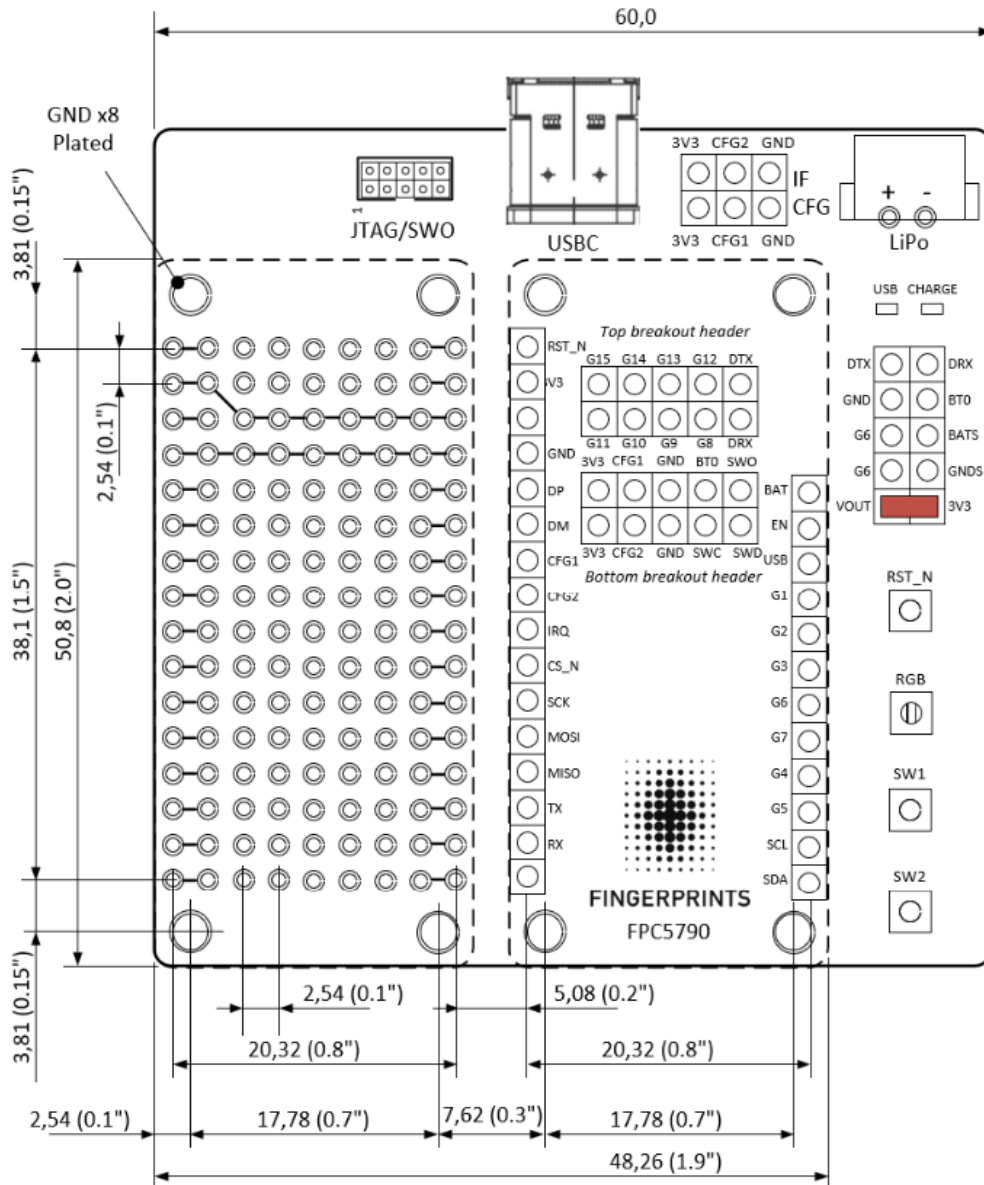

5.6 Functional schematic

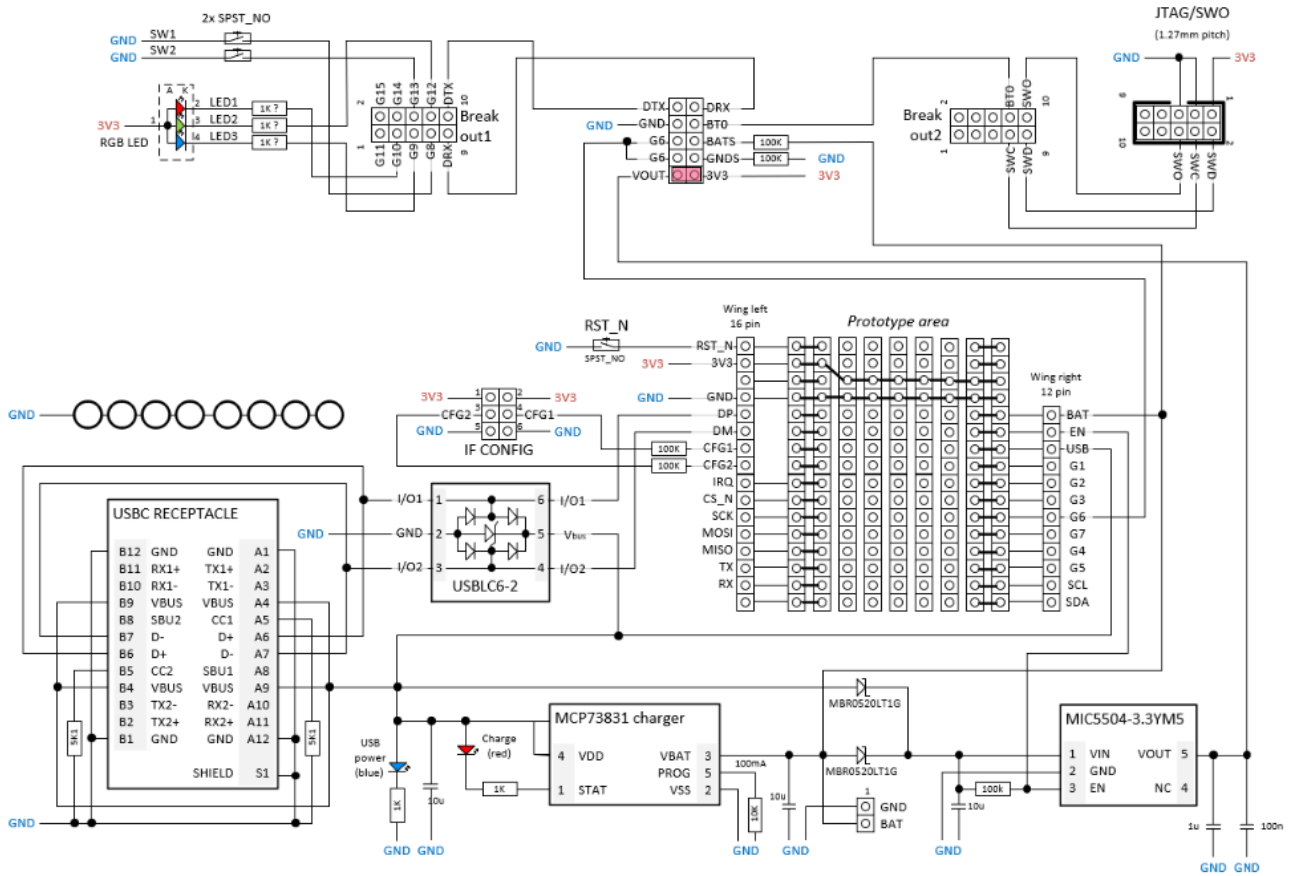

5.7 Prototype area

The prototype area contains through plated holes without any further connections, and holes duplicating the FingerWing signals. Pins are described from left to right in a matrix format (COL/ROW). Connections without a specific signal names are termed (COL/ROW).

Prototype area:

ROW	COL 1	COL 2	COL 3	COL 4	COL 5	COL 6	COL 7	COL 8	COL 9
1	RST_N	RST_N	-	-	-	-	-	COL 9/1	COL 8/1
2	3V3	3V3	-	-	-	-	-	COL 9/2	COL 8/2
3	-	NC	3V3	3V3	3V3	3V3	3V3	3V3	3V3
4	GND	GND	GND	GND	GND	GND	GND	GND	GND
5	DP	DP	-	-	-	-	-	BAT	BAT
6	DM	DM	-	-	-	-	-	EN	EN
7	CFG1	CFG1	-	-	-	-	-	USB	USB
8	CFG2	CFG2	-	-	-	-	-	G1	G1
9	IRQ	IRQ	-	-	-	-	-	G2	G2
10	CS_N	CS_N	-	-	-	-	-	G3	G3
11	SCK	SCK	-	-	-	-	-	G6	G6
12	MOSI	MOSI	-	-	-	-	-	G7	G7
13	MISO	MISO	-	-	-	-	-	G4	G4
14	TX	TX	-	-	-	-	-	G5	G5
15	RX	RX	-	-	-	-	-	SCL	SCL
16	-	NC	-	-	-	-	-	SDA	SDA

5.8 Interface selection

Different Biometric System products offers different interfaces. In order to select the desired interface, two configuration pins on the LGA are used. These pins can be hard wired high (3V3) or low (GND) in the final application, when the final interface is selected, assuming only one interface is used.

INTERFACE	CFG1	CFG2
SPI	LOW	LOW
UART	HIGH	LOW
USB	LOW	HIGH
I ² C	HIGH	HIGH

Interface configuration can also be set in SW or manually on the FingerTwin using jumpers. If they are left open (not set), SPI is the default interface. Also pay attention to any hard-wired interface selection done on the FingerWing. Conflicting interface selection will lead to interface malfunction.

SPI interface set:

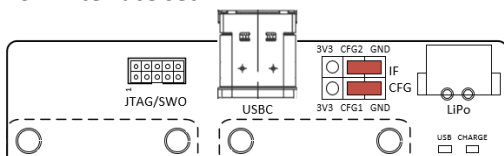

UART interface set:

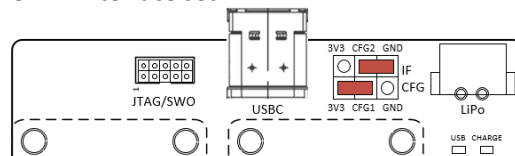

6 FPC5792 FLEX (12P) BREAKOUT BOARD

6.1 Overview

The flex breakout board is provided to simplify initial module evaluation and early prototyping. All pins are exposed for easy access. On top of this interface selection can be hardwired directly on the breakout board as well as EGND and GND connection.

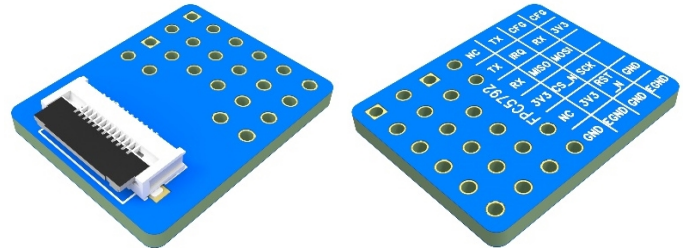

6.2 Product outline

On delivery the breakout board is provided with a ZIF connector only. Remaining terminals are left open and ready for connection to serial adapters or pin-to-pin wiring.

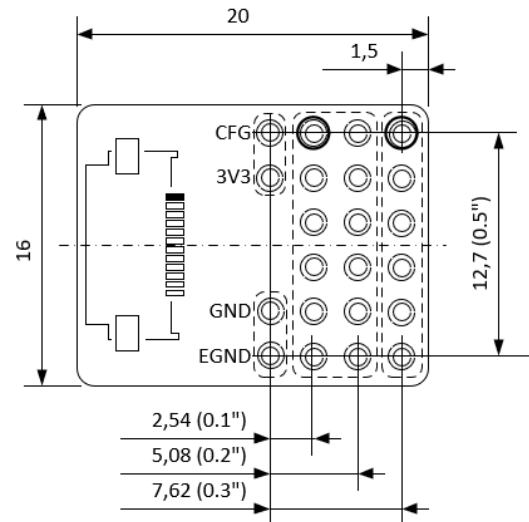

6.3 Functional schematic

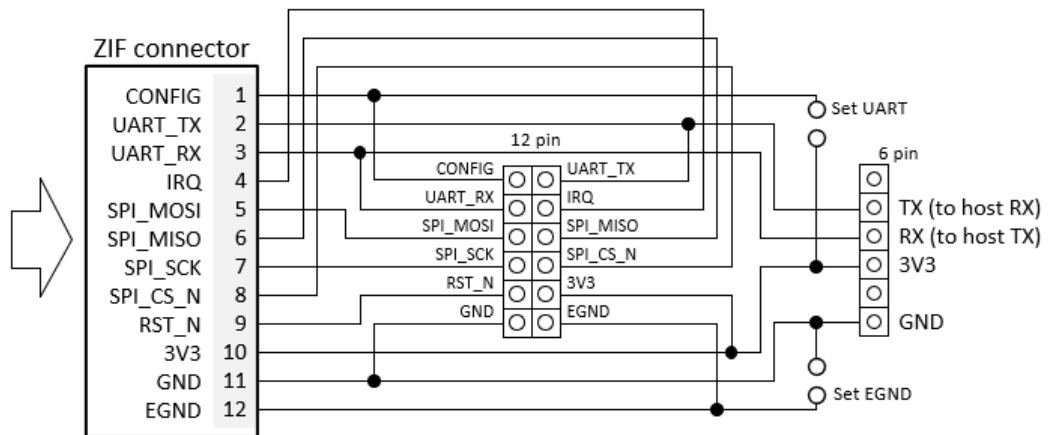

6.4 Pin configuration

Flex breakout board header (4x6 matrix):

SETUP	FLEX BREAKOUT				SERIAL ADAPTOR BREAKOUT	
CFG	CONFIG (PIN 1)	UART_TX (PIN 2)			NC (PIN 1)	
3V3	UART_RX (PIN 3)	IRQ (PIN 4)			TX (PIN 2)	
-	SPI_MOSI (PIN 5)	SPI_MISO (PIN 6)			RX (PIN 3)	
-	SPI_SCK (PIN 7)	SPI_CS_N (PIN 8)			3V3 (PIN 4)	
GND	RST_N (PIN 9)	3V3 (PIN 10)			NC (PIN 5)	
EGND	GND (PIN 11)	EGND (PIN 12)			GND (PIN 6)	

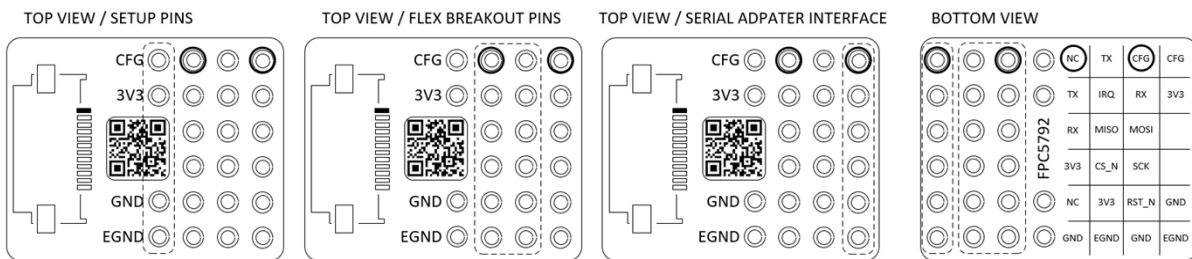

6.5 Interface selection and ESD discharge path

Interface configuration can be set in SW or manually (hard wired) on the flex breakout board with a wire jumper. To use UART the jumper need to be set, if the jumper is left open SPI is the default interface. No wire jumpers are mounted on delivery.

More information on available interfaces and how to set the required interface is provided in each Biometric System specification.

If an external protective ground is available, EGND can be connected directly to this terminal. Otherwise EGND should be shorted to GND. Note the EGND should not be left open (not connected) since this will disable the built-in ESD discharge protection.

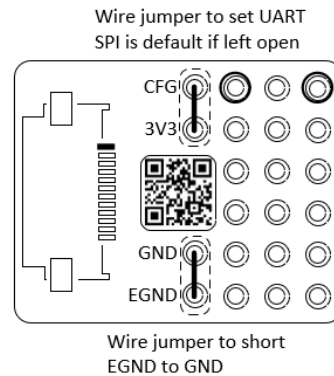

6.6 DEEP SLEEP wakeup in UART mode

The steps to wake up a Biometric system from DEEP SLEEP in UART mode, is described more in detail under the "Interface/UART communication" section in the corresponding Biometric Systems specification. But in general below method can be applied.

As described in the above-mentioned section, if no separate signal is assigned as system wakeup, e.g. using a common USB-to-serial adaptor, a dedicated jumper is required between CS_N (SYS_WU in UART mode) and UART_RX. This will allow the system to wake up using only the UART_RX signal.

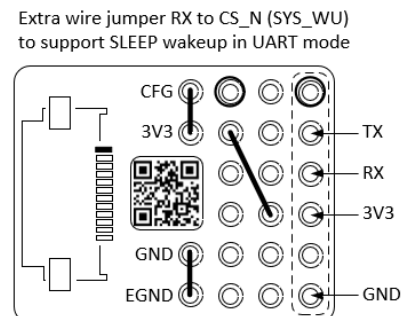

7 ORDERING INFORMATION

7.1 Device name and Part numbers

PRODUCT	PART #	DESCRIPTION
AllKey Devkit	100026231	Development Kit with FPC2532 AllKey
AllKey Pro Devkit	100026232	Development Kit with FPC2534 AllKey Pro
AllKey Open Platform Devkit	100026312	Development Kit with FPC2541 AllKey Open Platform
AllKey Ultra Devkit	100026313	Development Kit with FPC3530 AllKey Ultra
FPC5789-2532	100026224	FPC FingerWing with FPC2532 AllKey
FPC5789-2534	100026225	FPC FingerWing with FPC2534 AllKey Pro
FPC5789-2541		FPC FingerWing with FPC2541 AllKey Open Platform
FPC5793-3530	100026299	FPC FingerWing with FPC3530 AllKey Ultra
FPC5795-3510	100026300	FPC FingerWing with FPC3510 AllKey Ultra Edge
FPC5788	100026211	FPC Arduino Shield, allowing connection with a FingerWing
FPC5790	100026264	FPC FingerTwin, USB powered and allowing connection with a FingerWing
FPC5792	100026229	Flex break-out, 12 pin ZIF with interface selection

7.2 Production codes

Devices are labeled with a QR code.

ITEM	REFERENCE DESIGNATION	LENGTH
Part number	NNNNNNNNN (FPC part number)	9 characters
Hardware revision	1A	2 characters
Supplier batch number	DDDDDDDDDD (up to)	12 characters
Manufacturing year	YY	2 characters
Manufacturing week	WW	2 characters

Example QR code string: 100026224-1A-DDDDDDDD-2418



7.3 Shipping format

Development boards are in general supplied in ESD safe packing material/wrapping/boxes. Boxes are marked with necessary product information, both text and barcode.

7.4 ESD sensitive device

Proper handling shall be ensured during device assembly.

8 REVISION HISTORY

8.1 Product specification (this document)

REVISION	DESCRIPTION	RELEASE DATE
1	Initial release	Dec 2025

9 CONTACT INFORMATION

Fingerprint Cards AB (FPC)

Main office
P.O. Box 2412
SE-403 16, Gothenburg
Sweden

Web site
www.fpc.com

Sales contact information: sales@fpc.com